

---

Transaction  
**4010**

---

---

Set **812**, Version

---

ANSI Standard Version 4010

Segments used by Home Shopping Network for **Drop Ship** Credit/Debit Notifications

**SEGMENT ISA - INTERCHANGE CONTROL HEADER**

**PURPOSE**

To start and identify an interchange of one or more functional groups and interchange-related control segments.

**EDI STANDARD SEGMENT**

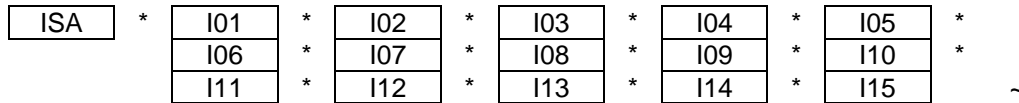

**HSN SUBSET OF EDI STANDARD SEGMENT**

Same as the EDI Standard Segment

ELEMENT NUMBER	ELEMENT NAME/DESCRIPTION	ELEMENT ATTRIBUTES	COMMENTS
ISA	SEGMENT IDENTIFIER		"ISA"
I01 001	<b>AUTHORIZATION INFORMATION QUALIFIER</b> Code to identify the type of information in the Authorization Information.	(M IS 2/2)	" 00 "
I02 002	<b>AUTHORIZATION INFORMATION</b> Information used for additional identification or authorization of the sender or the data in the interchange. The type of information is set by the Authorization Information Qualifier.	(M AN 10/10)	blank
I03 003	<b>SECURITY COMMUNICATION QUALIFIER</b> Code to identify the type of information in the Security Information.	(M ID 2/2)	" 00 "
I04 004	<b>SECURITY INFORMATION</b> This is used for identifying the security information about the sender of the data in the interchange. The type of information is set by the Security Information Qualifier.	(M AN 10/10)	blank

<b>I05 005</b>	<b>INTERCHANGE ID QUALIFIER</b> Qualifier to designate the system/method of code structure used to designate the sender or receiver ID element being qualified.	(M ID 2/2)	Your interchange qualifier.
<b>I06 006</b>	<b>INTERCHANGE SENDER ID</b> Identification code published by the sender for other parties to use as the receiver ID to route data to them. The sender always codes this number in the sender ID element.	(M ID 15/15)	Your interchange ID.
<b>I05 007</b>	<b>INTERCHANGE ID QUALIFIER</b> Qualifier to designate the system/method of code structure used to designate the sender or receiver ID element being qualified.	(M ID 2/2)	HSN interchange qualifier. " 01 "
<b>I07 008</b>	<b>INTERCHANGE RECEIVER ID</b> Identification code published by the sender for other parties to use as the receiver ID to route data to them. The sender always codes this number in the sender ID element.	(M ID 15/15)	HSN interchange ID. " 076902113 "  "076902113T" (for testing)
<b>I08 009</b>	<b>INTERCHANGE DATE</b> Date of the interchange.	(M DT 6/6)	Interchange creation date (YYMMDD)
<b>I09 010</b>	<b>INTERCHANGE TIME</b> Time of the interchange	(M TM 4/4)	Interchange creation time. HHMM
<b>I10 011</b>	<b>INTERCHANGE CONTROL STANDARDS IDENTIFIER</b> Code to identify the agency responsible for the control standard used by the message that is enclosed by the interchange header and trailer.	(M ID 1/1)	" U "
<b>I11 012</b>	<b>INTERCHANGE CONTROL VERSION NUMBER</b> This version number converts the interchange control segments and the functional group control segments.	((M ID 5/5)	" 00401 "
<b>I12 013</b>	<b>INTERCHANGE CONTROL NUMBER</b> This number uniquely identifies the interchange data to the sender.	(M NO 9/9)	Your sequential number

<b>I13 014</b>	<b>ACKNOWLEDGMENT REQUESTED</b> Code sent by the sender to request an interchange acknowledgment.	(M ID 1/1)	" 0 "
<b>I14 015</b>	<b>TEST INDICATOR</b> Code to indicate whether data enclosed by this interchange envelope is test or production.	(M ID 1/1)	" P " = production " T " = test
<b>I15 016</b>	<b>SUBELEMENT SEPARATOR</b>	(M AN 1/1)	" > "

**SEGMENT GS - FUNCTION GROUP HEADING**

**PURPOSE**

To indicate the beginning of a functional group and to provide control information.

**EDI STANDARD SEGMENT**

GS	*	479	*	142	*	124	*	29	*	30	*	28	*
		455	*	480		~							

**HSN SUBSET OF EDI STANDARD SEGMENT**

Same as the EDI Standard Segment.

ELEMENT NUMBER	ELEMENT NAME/DESCRIPTION	ELEMENT ATTRIBUTES	COMMENTS
<b>GS</b>	<b>SEGMENT IDENTIFIER</b>		"GS"
<b>479 001</b>	<b>FUNCTIONAL IDENTIFIER CODE</b> Code identifying a group of application related Transaction Sets.	(M ID 2/2)	" CD "
<b>142 002</b>	<b>APPLICATION SENDER'S CODE</b> Code identifying party sending transmission.	(M AN 2/15)	Your interchange ID.
<b>124 003</b>	<b>APPLICATION RECEIVER'S CODE</b> Code identifying party receiving transmission.	(M AN 2/15)	HSN interchange ID " 076902113 "  "076902113T" (for testing)
<b>29 004</b>	<b>GROUP DATE</b> Date sender generated a group of transaction sets.	(M DT 8/8)	Your system date when group was created (CCYYMMDD).
<b>30 005</b>	<b>GROUP TIME</b> Time when the sender generated a group of transaction sets	(M TM 4/4)	Your local time when group was generated (HHMM).
<b>28 006</b>	<b>GROUP CONTROL NUMBER</b> Assigned number originated and maintained by the sender.	(M ID 1/9)	Your sequential number
<b>455 007</b>	<b>RESPONSIBLE AGENCY CODE.</b> Code used to identify the issuer of the standard.	(M ID 1/2)	" X " for ASC X12.
<b>480 008</b>	<b>VERSION/RELEASE/INDUSTRY ID CODE</b> Version and release information of the EDI standard being used.	(M ID 1/12)	" 004010 "

**SEGMENT ST - TRANSACTION SET HEADER**

**PURPOSE**

To indicate the start of a transaction set and to assign a control number.

**EDI STANDARD SEGMENT**

ST \* 143 \* 329 ~

**HSN SUBSET OF EDI STANDARD SEGMENT**

Same as EDI Standard Segment above.

<b>ELEMENT NUMBER</b>	<b>ELEMENT NAME/DESCRIPTION</b>	<b>ELEMENT ATTRIBUTES</b>	<b>COMMENTS</b>
ST	SEGMENT IDENTIFIER		"ST"
143 001	TRANSACTION SET IDENTIFIER CODE Code uniquely identifying a transaction set.	(M AN 3/3)	" 812 "
329 002	TRANSACTION SET CONTROL NUMBER Identifying control number assigned by the originator for a transaction set.	(M AN 4/9)	Your unique control number identifying a transaction set.

**SEGMENT BCD - BEGINNING CREDIT/DEBIT ADJUSTMENT**

**PURPOSE**

To transmit identifying dates and numbers for this transaction .

**EDI STANDARD SEGMENT**

BCD	*	373	*	475	*	305	*	610	*	478	*
		373	*	76	*	424	*	373	*	324	*
		353	*	640	*	128		127	~		
							~				

**HSN SUBSET OF EDI STANDARD SEGMENT**

BCD	*	373	*	475	*	305	*	610	*	478	*
			*		*	610			~		

ELEMENT NUMBER	ELEMENT NAME/DESCRIPTION	ELEMENT ATTRIBUTES	COMMENTS
BCD	SEGMENT IDENTIFIER		"BCD "
373 001	DATE	(M DT 8/8)	CCYYMMDD
475 002	CREDIT/DEBIT ADJUSTMENT Number assigned by issuer of a credit or debit memo.	(M AN 1/22)	"Credit Memo Number"
305 003	TRANSACTION HANDLING CODE Code designating the action to be taken by all parties.	(M ID 1/2)	"L"
610 004	AMOUNT Amount refunded. (Excludes Shipping & Handling)	(M N2 1/15)	"Amount Refunded"
478 005	CREDIT/DEBIT FLAG CODE Code indicating whether amount is a credit or debit.	(M ID 1/1)	"C"
373 006	DATE	(O DT 8/8)	**NOT USED**
76 007	INVOICE NUMBER	(C AN 1/22)	**NOT USED**
424 008	VENDOR ORDER NUMBER	(O AN 1/22)	**NOT USED**
373 009	DATE	(O DT 8/8)	**NOT USED**

**DROP SHIP**

<b>324</b> <b>010</b>	<b>PURCHASE ORDER NUMBER</b> Identifying number for Purchase Order assigned by the orderer/purchaser. Retailer's original purchase order number.	(C AN 1/22)	<b>HSN Mandatory</b> Purchase order number (850 BEG 03)
<b>353</b> <b>011</b>	<b>TRANSACTION CODE PURPOSE</b>	(O ID 2/2)	**NOT USED**
<b>640</b> <b>012</b>	<b>TRANSACTION TYPE CODE</b>	(O ID 2/2)	**NOT USED**
<b>128</b> <b>013</b>	<b>REFERENCE NUMBER QUALIFIER</b>	(C ID 2/3)	**NOT USED**
<b>127</b> <b>014</b>	<b>REFERENCE NUMBER</b>	(C AN 1/30)	**NOT USED**
<b>306</b> <b>015</b>	<b>Action Code</b>	(O ID 1/2)	**NOT USED**



**SEGMENT N1 - NAME**

**PURPOSE**

To identify a party by type of organization, name and code.

**EDI STANDARD SEGMENT**

N1 \* 98 \* 93 \* 66 \* 67 ~

**HSN SUBSET OF EDI STANDARD SEGMENT**

N1 \* 98 \* 93 \* 66 \* 67 ~

<b>ELEMENT NUMBER</b>	<b>ELEMENT NAME/DESCRIPTION</b>	<b>ELEMENT ATTRIBUTES</b>	<b>COMMENTS</b>
<b>N1</b>	<b>SEGMENT IDENTIFIER</b>		“ N1 ”
<b>98 001</b>	<b>ENTITY IDENTIFIER CODE</b> Code identifying an organizational entity, a physical location, or an individual.	(M ID 2/2)	“ SU “
<b>93 002</b>	<b>NAME</b> Free-form name.	(M AN 1/35)	<b>HSN Mandatory</b> Vendor Company Name
<b>66 003</b>	<b>IDENTIFICATION CODE QUALIFIER</b> Code designating the system/method of code structure used for Identification Code (67).	(M ID 2/2)	<b>HSN Mandatory</b> “ 92 “
<b>67 004</b>	<b>IDENTIFICATION CODE</b> Code identifying a party or other code.	(M AN 2/17)	<b>HSN Mandatory</b> HSN Internal Vendor Number

**SEGMENT CDD - CREDIT/DEBIT ADJUSTMENT DETAIL**

**PURPOSE**

To provide information relative to a line item adjustment.

**EDI STANDARD SEGMENT**

CDD	*	426	*	478	*	350	*	610	*	823	*	417	*
		477	*	355	*	427	*	236	*	212	*	236	*
		212		~									

**HSN SUBSET OF EDI STANDARD SEGMENT**

CDD	*	426	*	*	*	*	*	477	*	355	*	*	236	*	212	~
-----	---	-----	---	---	---	---	---	-----	---	-----	---	---	-----	---	-----	---

ELEMENT NUMBER	ELEMENT NAME/DESCRIPTION	ELEMENT ATTRIBUTES	COMMENTS
CDD	SEGMENT IDENTIFIER		"CDD"
426 001	ADJUSTMENT REASON CODE Code indicating reason for credit memo, or adjustment to invoice, credit memo, or payment.	(M ID 2/2)	<b>HSN Mandatory</b> HSN return reason code Valid reason codes: 01=Didn't fit 02=Not as expected 03=Broken/Doesn't work 07=Wrong item 13=Workmanship 17=No Reason supplied 21=Not what I expected 28=Difficult to assemble or use 36=Damaged in delivery 46=Refused/Returned to Customer – to old
478 002	CREDIT/DEBIT FLAG CODE	(M ID 1/1)	"C"
350 003	ASSIGNED IDENTIFICATION	(O AN 1/20)	**NOT USED**
610 004	AMOUNT	(C N2 1/15)	**NOT USED**
823 005	RETURN FLAG CODE	(O ID 1/1)	**NOT USED**
417 006	PRICE BRACKET IDENTIFIER	(O AN 1/3)	**NOT USED**
477 007	CREDIT/DEBIT QUANTITY Number of supplier units credited or debited.	(C R 1/10)	<b>HSN Mandatory</b> Quantity returned (Length = 3, must be zero filled)
355 008	UNIT OR BASIS FOR MEASUREMENT CODE Code specifying the units in which a value is being expressed, or manner in which a measurement has been taken.	(C ID 2/2)	<b>HSN mandatory</b> "EA"

NOTE REGARDING THE COMMENTS FIELD: Actual values are contained within quotes.

***DROP SHIP***

427 009	<b>UNIT PRICE DIFFERENCE</b>	(O R 1/5)	**NOT USED**
236 010	<b>PRICE IDENTIFIER CODE</b>	(C ID 3/3)	SLP (suggested retail price)
212 011	<b>UNIT PRICE</b> Price per unit of product, service. commodity, etc.	(C R 1/17)	<b>HSN mandatory</b> member retail price (from 850 CTP03)
236 012	<b>PRICE IDENTIFIER CODE</b>	(C ID 3/3)	**NOT USED**
212 013	<b>UNIT PRICE</b>	(C R 1/17)	**NOT USED**

**SEGMENT LIN – ITEM IDENTIFICATION**

**PURPOSE**

To provide information relative to item information.

**EDI STANDARD SEGMENT**

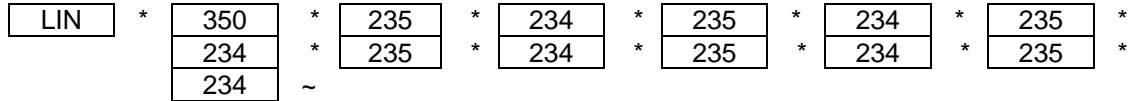

**HSN SUBSET OF EDI STANDARD SEGMENT**

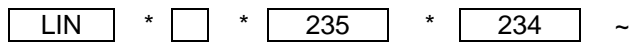

ELEMENT NUMBER	ELEMENT NAME/DESCRIPTION	ELEMENT ATTRIBUTES	COMMENTS
LIN	ELEMENT IDENTIFIER		"LIN"
350	ASSIGNED IDENTIFICATION	(O AN 1/11)	**NOT USED**
001			
235	PRODUCT SERVICE ID/QUAL	(M ID 2/2)	<b>HSN Mandatory</b>
002			'IT'
234	PRODUCT SERVICE ID	(M AN 1/48)	<b>HSN Mandatory</b>
003			HSN Item Number (from 850 P0109)

---

NOTE REGARDING THE COMMENTS FIELD: Actual values are contained within quotes.

**SEGMENT SE - TRANSACTION SET TRAILER**

**PURPOSE**

To indicate the end of the transaction set and provide the count of the transmitted segments (including the beginning (ST) and the ending (SE) segments).

**EDI STANDARD SEGMENT**

SE \* 96 \* 329 ~

**HSN SUBSET OF EDI STANDARD SEGMENT**

Same as the EDI Standard Segment.

ELEMENT NUMBER	ELEMENT NAME/DESCRIPTION	ELEMENT ATTRIBUTES	COMMENTS
SE	SEGMENT IDENTIFIER		"SE"
96 001	<b>NUMBER OF INCLUDED SEGMENTS</b> Total number of segments included in a transaction set including ST and SE segments.	(M NO 1/1)	Total number of segments included in the ST – SE group
329 002	<b>TRANSACTION SET CONTROL NUMBER</b> Identifying control number that must be unique within the transaction set functional group assigned by the originator for a transaction set.	(M AN 4/9)	Your sequential number

**SEGMENT GE - FUNCTIONAL GROUP TRAILER**

**PURPOSE**

To indicate the end of a functional group and to provide control.

**EDI STANDARD SEGMENT**

GE \* 97 \* 28 ~

**HSN SUBSET OF EDI STANDARD SEGMENT**

Same as EDI Standard Segment

ELEMENT NUMBER	ELEMENT NAME/DESCRIPTION	ELEMENT ATTRIBUTES	COMMENTS
GE	SEGMENT IDENTIFIER		" GE "
97 001	<b>NUMBER OF TRANSACTION SETS INCLUDED.</b> Count of ST segments within the Group.	(M NO 1/6)	Total number of transaction sets included in the GS - GE group.
28 002	<b>GROUP CONTROL NUMBER</b> Assigned number originated and maintained by the sender.	(M NO 1/9)	Same number as in GS segment (data element 06)

**SEGMENT IEA - INTERCHANGE CONTROL TRAILER**

**PURPOSE**

To define the end of an interchange of one or more functional groups and interchange-related control segments.

**EDI STANDARD SEGMENT**

IEA \* I16 \* I12 ~

**HSN SUBSET OF EDI STANDARD SEGMENT**

Same as EDI Standard Segment.

<b>ELEMENT NUMBER</b>	<b>ELEMENT NAME/DESCRIPTION</b>	<b>ELEMENT ATTRIBUTES</b>	<b>COMMENTS</b>
<b>IEA</b>	<b>SEGMENT IDENTIFIER</b>		" IEA "
<b>I16 001</b>	<b>NUMBER OF INCLUDED FUNCTIONAL GROUPS</b> A count of the number of included groups included in a transmission.	(M N0 1/5)	Count of the GS segments in the transmission.
<b>I12 002</b>	<b>INTERCHANGE CONTROL NUMBER</b> Number that uniquely identifies the interchange data. It is assigned by the sender.	(M N0 9/9)	Same number as in the ISA segment (data element 13)

**TRANSACTION LAYOUT**

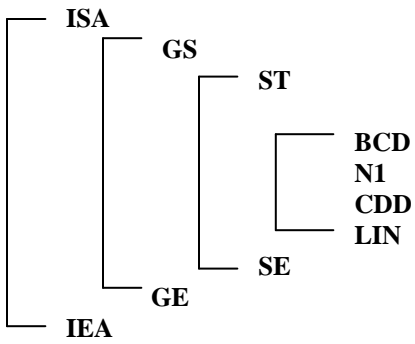



**SAMPLE TRANSACTION**

ISA\*00\*                   \*00\*                   \*01\*106092654                   \*01\*076902113  
\*000509\*1608\*U\*00401\*000000459\*0\*P\*>  
GS\*CD\*106092654\*076902113\*20000509\*1608\*459\*X\*004010  
ST\*812\*36923  
BCD\*20000509\*4711731\*L\*1550\*C\*\*\*\*\*414711731  
N1\*SU\*MOOSF Corp\*92\*98783  
CDD\*01\*C\*\*\*\*\*1\*EA\*\*SLP\*15.50  
LIN\*\*IT\*1201682  
SE\*6\*36923  
ST\*812\*36924  
BCD\*20000509\*1596652\*L\*1300\*C\*\*\*\*\*421596652  
N1\*SU\*MOOSF Corp\*92\*98783  
CDD\*01\*C\*\*\*\*\*1\*EA\*\*SLP\*13.00  
LIN\*\*IT\*1516851  
SE\*6\*36924  
ST\*812\*36925  
BCD\*20000509\*1596769\*L\*1300\*C\*\*\*\*\*421596769  
N1\*SU\*MOOSF Corp\*92\*98783  
CDD\*01\*C\*\*\*\*\*1\*EA\*\*SLP\*13.00  
LIN\*\*IT\*151685885090010  
SE\*6\*36925  
ST\*812\*36926  
BCD\*20000509\*1597521\*L\*1300\*C\*\*\*\*\*421597521  
N1\*SU\*MOOSF Corp\*92\*98783  
CDD\*01\*C\*\*\*\*\*1\*EA\*\*SLP\*13.00  
LIN\*\*IT\*151685100090006  
SE\*6\*36926  
ST\*812\*36927  
BCD\*20000509\*1599546\*L\*1300\*C\*\*\*\*\*421599546  
N1\*SU\*MOOSF Corp\*92\*98783  
CDD\*01\*C\*\*\*\*\*1\*EA\*\*SLP\*13.00  
LIN\*\*IT\*151685450070006  
SE\*6\*36927  
GE\*5\*459  
IEA\*1\*000000459