

GOTTSCHALKS INC.

7 RIVER PARK PLACE EAST
FRESNO, CALIFORNIA 93720

**EDI MAPPING SPECIFICATIONS
VERSION 004030VICS
850 - PURCHASE ORDER**

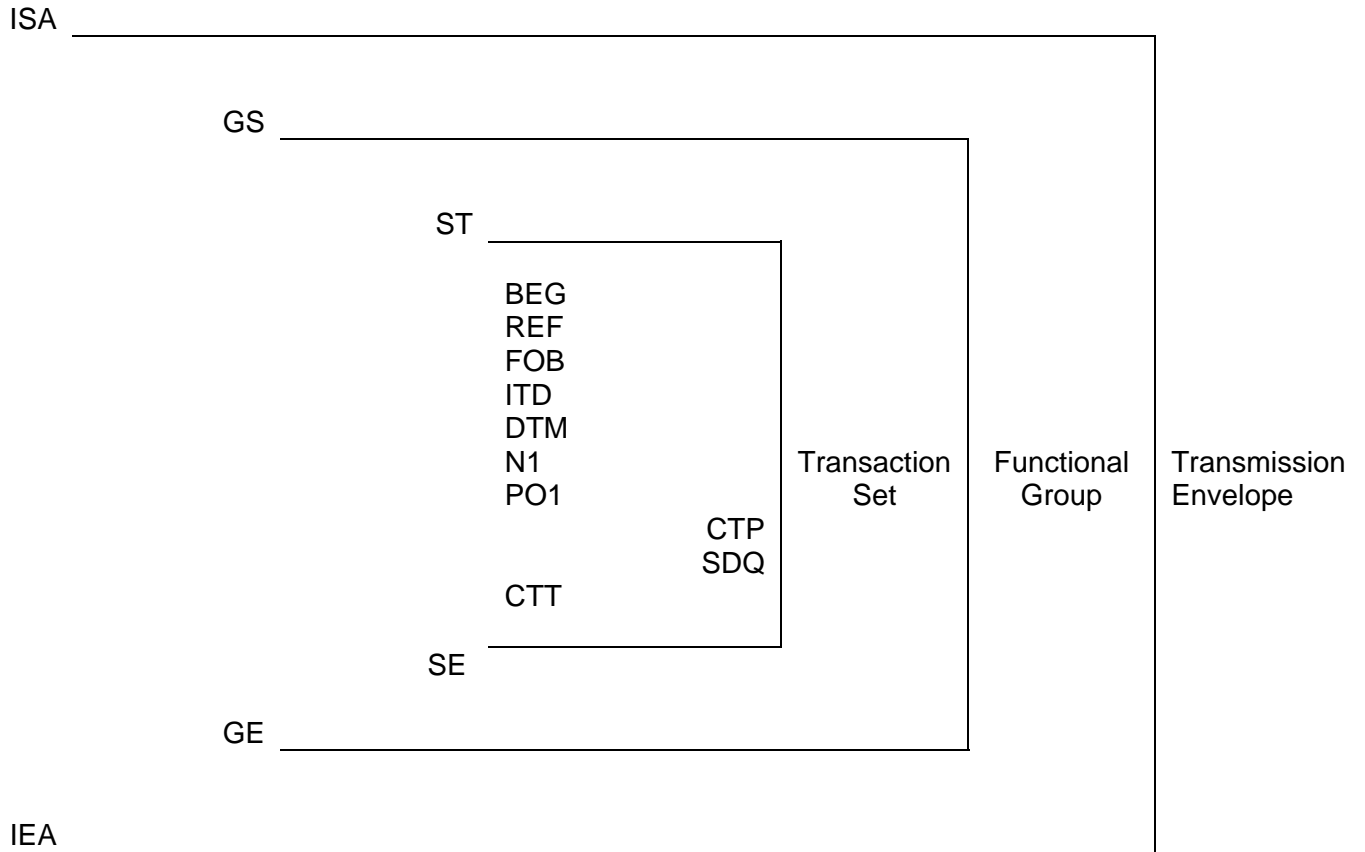

DATA ELEMENT DELIMITER * (asterisk)

SUBELEMENT SEPARATOR > (greater than)

SEGMENT TERMINATOR ~ (tilde)

GOTTSCHALKS**850 PURCHASE ORDER: 004030VICS**

<u>SEGMENT</u>	<u>DATA ELEMENT</u>	<u>LEN</u>	<u>VALUE/COMMENTS</u>	
ISA	ISA01	Qualifier	2	"00"
	ISA02	Authorization	10	Blanks
	ISA03	Qualifier	2	"00"
	ISA04	Security	10	Blanks
	ISA05	Qualifier	2	"01"
	ISA06	Sender I.D.	15	147575138"
	ISA07	Qualifier	2	Receiver's Qualifier
	ISA08	Receiver I.D.	15	Receiver's I.D. Number
	ISA09	Date	6	YYMMDD
	ISA10	Time	4	HHMM
	ISA11	Control Standards Identifier	1	"U" (ASC X12)
	ISA12	Version	5	"00403"
	ISA13	Control Number	9	Sequential Number
	ISA14	Req. Acknowledgement	1	"0" (No)
	ISA15	Test Indicator	1	"P" (Prod.) or "T" (Test)
	ISA16	Component Element Separator	1	">"
GS	GS01	I.D.	2	"PO"
	GS02	Sender	9	"147575138" (Duns)
	GS03	Receiver	2-15	Receiver's I.D. Number
	GS04	Date	8	CCYYMMDD
	GS05	Time	4-8	HHMM, HHMMSS, HHMMSSD, or HHMMSSDD
	GS06	Control Number	1-9	Sequential Number
	GS07	Agency	1	"X" (ASC X12)
	GS08	Version	10	"004030VICS"
ST	ST01	Transaction Set I.D.	3	"850"
	ST02	Control Number	4-9	Sequential Number
BEG	BEG01	Purpose	2	"00" (Original) Default code "06" (Confirmation) "07" (Duplicate)
	BEG02	Type	2	"SA" (Stand Alone) "BK" (Blanket Order) "RL" (Release or Delivery Order) "RE" (Reorder)
	BEG03	PO Number	6	Purchase Order Number
	BEG05	PO Date	8	CCYYMMDD
REF	REF01	Qualifier	2	"DP" (Department)
	REF02	Number	3	Retailer's Dept. Number
FOB	FOB01	Shipment Payment	2	"CC", "PP"
	FOB02	FOB	2	"OR", "DE", "FE"
ITD	ITD01	Terms	2	"05" (Net), "08" (Basic Discount Offered), "12" (10EOM)
	ITD02	Date Code	1	"2" (Delivery Date)
	ITD03	Term Disc. %	1-6	0-99

GOTTSCHALKS**850 PURCHASE ORDER: 004030VICS**

<u>SEGMENT</u>	<u>DATA ELEMENT</u>	<u>LEN</u>	<u>VALUE/COMMENTS</u>
ITD	ITD05	Terms Disc. Days Due	1-3 0-999
	ITD07	Terms Net Days	1-3 0-999
	ITD12	Description	1-80 Freeform
	ITD13	Day of Month	1-2 1-31
DTM	DTM01	Date/Time Qualifier	3 "037" (Ship Not Before)
	DTM02	Date	8 CCYYMMDD
DTM	DTM01	Date/Time Qualifier	3 "001" (Cancel After)
	DTM02	Date	8 CCYYMMDD
N1	N101	Entity I.D.	2 "ST" (Ship To)
	N102	Description of N101	31 "Gottschalks Distribution Center"
	N103	ID Qualifier	2 "92" (Assigned by Buyer)
	N104	ID Code	3 "094" (D.C. Number) – Madera, CA "097" (D.C. Number) – Madera, CA
PO1	PO101	Line Number	1-6 Line Number
	PO102	Order Quantity	1-15 Quantity Ordered
	PO103	Unit of Measure	2 "EA", "PK", "DZ", "PR", "CA"
	PO104	Price	1-17 Wholesale Price
	PO106	Qualifier	2 "UP" or "EN"
	PO107	Product	12-13 UPC or EAN Code for Item
	CTP	CTP01	Class of Trade Code
	CTP02	Price I.D. Code	3 "RTL" (new code)
	CTP03	Unit Price	1-17 Retail Price
*SDQ	SDQ01	Unit of Measure Code	2 "EA", "PK", "DZ", "PR", "CA"
	SDQ02	Location Code	2 "92" (Assigned by Buyer)
	SDQ03	Location	3 Retailers Store Number
	SDQ04	Quantity	1-15 Quantity of UPC/EAN
CTT	CTT01	Line Item Count	1-6 Number of PO1 Segments
SE	SE01	Total Segments	1-10 Segment Count; includes ST & SE
	SE02	Control Number	4-9 Sequential Number; same as ST02
GE	GE01	Total	1-6 Total of ST Segments
	GE02	Control Number	1-9 Sequential Number; same as GS06
IEA	IEA01	Total	1-5 Total of GS Segments
	IEA02	Control Number	9 Sequential Number, same as ISA13

*Up to 10 Store location/quantity elements for each SDQ segment.

GOTTSCHALKS INC.

7 RIVER PARK PLACE EAST
FRESNO, CALIFORNIA 93720

**EDI MAPPING SPECIFICATIONS
VERSION 004030VICS
810 -INVOICE**

GOTTSCHALKS**810 INVOICE: 004030VICS**

<u>SEGMENT</u>	<u>DATA ELEMENT</u>	<u>LEN</u>	<u>VALUE/COMMENTS</u>
ISA	ISA01	Qualifier	2 "00"
	ISA02	Authorization	10 Blanks
	ISA03	Qualifier	2 "00"
	ISA04	Security	10 Blanks
	ISA05	Qualifier	2 Sender's Qualifier
	ISA06	Sender I.D.	15 Sender's I.D. Number
	ISA07	Qualifier	2 "01"
	ISA08	Receiver I.D.	15 "147575138"
	ISA09	Date	6 YYMMDD
	ISA10	Time	4 HHMM
	ISA11	Standard I.D.	1 "U" (ASC X12)
	ISA12	Version	5 "00403"
	ISA13	Control Number	9 Sequential Number
	ISA14	Req. Acknowledgement	1 "0" (No)
	ISA15	Test Indicator	1 "P" (Prod.) or "T" (Test)
	ISA16	Component Element Separator	1 ">"
GS	GS01	I.D.	2 "IN"
	GS02	Sender	2-15 Sender's I.D.
	GS03	Receiver	9 "147575138" (Duns)
	GS04	Date	8 CCYYMMDD
	GS05	Time	4-8 HHMM, HHMMSS, HHMMSSD, or HHMMSSDD
	GS06	Control Number	1-9 Sequential Number
	GS07	Agency	1 "X" (ASC X12)
	GS08	Version	10 "004030VICS"
ST	ST01	Transaction Set I.D.	3 "810"
	ST02	Control Number	4-9 Sequential Number
BIG	BIG01	Invoice Date	8 CCYYMMDD
	BIG02	Invoice Number*	1-22 Assigned by Vendor
	BIG03	Purchase Order Date	8 CCYYMMDD
	BIG04	Purchase Order Number	1-10 Assigned by Retailer
*Currently only able to accept 1-18 digit invoice numbers.			
REF	REF01	Qualifier	2 "DP" (Department)
	REF02	Number	3 Retailer's Dept. Number
N1	N101	Entity I.D. Code	2 "BT (Bill To) or "BY" (Buying Party)
	N103	I.D. Code Qualifier	2 "92" (Assigned by Retailer)
	N104	I.D.	2-17 Store Number being Invoiced

PLEASE NOTE: The following N101 element has been changed from 'RE' to 'RI'.

N1	N101	Entity I.D. Code	2 "RI" (Remit To)
	N103	I.D. Code Qualifier	1-2 "1" or "9".
	N104	I.D.	2-17 Vendor's DUNS Number
N3 (Optional)	N301	Address Information	1-35 Pay To Address

GOTTSCHALKS**810 INVOICE: 004030VICS**

<u>SEGMENT</u>	<u>DATA ELEMENT</u>	<u>LEN</u>	<u>VALUE/COMMENTS</u>	
N4 (Optional)	N401	City Name	2-30	Pay To City Name
	N402	State of Province Code	2	Pay to State or Province Code
	N403	Postal Code	3-9	Pay to Zip Code
ITD (SEE EXAMPLES)	ITD01	Terms Type Code	2	Terms Code
	ITD02	Terms Basis Date Code	1	"2" (Delivery Date) "3" (Invoice Date)
	ITD03	Term Disc. %	1-6	0-99 (if applicable)
	ITD04	Terms Disc. Due Date	8	CCYYMMDD (if applicable)
	ITD05	Terms Disc. Days Due	1-3	0-999 (if applicable)
	ITD06	Terms Net Due Date	8	CCYYMMDD (if applicable)
	ITD07	Terms Net Days	1-3	0-999 (if applicable)
ITD12	Description	1-80	Freeform	
IT1	IT101	Assigned I.D.	1-6	Sequentially Assigned Number Beginning with 1
	IT102	Quantity Invoiced	1-10	Quantity Invoiced
	IT103	Unit of Measurement Code	2	"EA", "DZ", "CA"
	IT104	Unit Price	1-14	Unit Price
	IT106	Prod. I.D. Qualifier	2	"UP", "EN"
	IT107	Product I.D.	2-13	UPC/EAN Code
TDS	TDS01	Total Invoice Amount	1-10	Total Invoice Amount
ISS	ISS01	Number of Units Shipped	1-10	Total Cartons Shipped
	ISS02	Unit of Meas. Code	2	"PK", "CA", "CT"
	ISS03	Weight (Optional)	1-10	Total Shipment Weight
	ISS04	Unit of Meas. Code (Optional)	2	"LB"
CTT	CTT01	Line Item Count	1-6	Number of IT1 Segments
SE	SE01	Total Segments	1-10	Segment Count; includes ST & SE
	SE02	Control Number	4-9	Sequential Number; same as ST02
GE	GE01	Total	1-6	Total of ST Segments
	GE02	Control Number	1-9	Sequential Number; same as GS06
IEA	IEA01	Total	1-5	Total of GS Segments
	IEA02	Control Number	9	Sequential Number, same as ISA13

ITD TERMS EXAMPLES

Example: Net

ITD01 = "05"
ITD02 = "2" or "3"
ITD06 = CCYYMMDD

Example: Net 30

ITD01 = "05"
ITD02 = "2" or "3"
ITD06 = CCYYMMDD
ITD07 = "30"

Example: Net 10 EOM

ITD01 = "12"
ITD02 = "2" or "3"
ITD06 = CCYYMMDD (Optional)

Example: 8/10 EOM

ITD01 = "12"
ITD02 = "2" or "3"
ITD03 = "8"
ITD04 = CCYYMMDD

Example: 8/30

ITD01 = "08"
ITD02 = "2" or "3"
*ITD03 = "8"
ITD04 = CCYYMMDD
*ITD05 = "30"

All due dates are determined by Invoice Date and Terms.

* These fields must be non-zero.

GOTTSCHALKS INC.

7 RIVER PARK PLACE EAST
FRESNO, CALIFORNIA 93720

**EDI MAPPING SPECIFICATIONS
VERSION 004030VICS
856 - SHIP NOTICE/MANIFEST**

GOTTSCHALKS**856 SHIP NOTICE/MANIFEST: 004030VICS**

<u>SEGMENT</u>	<u>DATA ELEMENT</u>	<u>LEN</u>	<u>VALUE/COMMENTS</u>	
ISA	ISA01	Qualifier	2	"00"
	ISA02	Authorization	10	Blanks
	ISA03	Qualifier	2	"00"
	ISA04	Security	10	Blanks
	ISA05	Qualifier	2	Sender's Qualifier
	ISA06	Sender I.D.	15	Sender's ID Number
	ISA07	Qualifier	2	"01"
	ISA08	Receiver I.D.	15	"147575138"
	ISA09	Date	6	YYMMDD
	ISA10	Time	4	HHMM
	ISA11	Standard I.D.	1	"U" (ASC X12)
	ISA12	Version	5	"00403"
	ISA13	Control Number	9	Sequential Number
	ISA14	Req. Acknowledgement	1	"0" (No)
	ISA15	Test Indicator	1	"P" (Prod.) or "T" (Test)
	ISA16	Component Element Separator	1	">"
GS	GS01	I.D.	2	"SH"
	GS02	Sender	2-12	Sender's ID Number
	GS03	Receiver	9	"147575138"
	GS04	Date	8	CCYYMMDD
	GS05	Time	4-8	HHMM, HHMMSS, HHMMSSD, or HHMMSSDD
	GS06	Control Number	1-9	Sequential Number
	GS07	Agency	1	"X" (ASC X12)
	GS08	Version	10	"004030VICS"
ST	ST01	Transaction Set I.D.	3	"856"
	ST02	Control Number	4-9	Sequential Number
BSN	BSN01	Transaction Set Purpose Code	2	"00" (Original)
	BSN02	Shipment ID	2-30	Unique number to ID Shipment
	BSN03	Date	8	CCYYMMDD
	BSN04	Time	4	HHMM
	BSN05	Hierarchical Structure Code	4	"0001" (Shipment, Order, Pack, Item)
HL	HL01	Hierarchical ID Number	1-12	"1" (Shipment)
	HL03	Hierarchical Level Code	1-2	"S" (Shipment)
TD1	TD101	Packaging Code	5	"CTN25", "CTN76", ETC.
	TD102	Lading Quantity	1-7	No. of Cartons in Shipment
	TD106	Weight Qualifier	1-2	"G" Gross
	TD107	Weight	1-10	Total Weight of Shipment
	TD108	Unit of Measure Code	2	"LB" (Pounds)
TD5	TD505	Routing	1-35	Description of Carrier
REF	REF01	Reference Number Qualifier	2	"BM" (Bill of Lading Number)
	REF02	Reference Number	1-30	BOL Number (Must be non-zero number)

<u>SEGMENT</u>	<u>DATA ELEMENT</u>	<u>LEN</u>	<u>VALUE/COMMENTS</u>	
DTM	DTM01	Date/Time Qualifier	3	"011"
	DTM02	Date	8	CCYYMMDD
N1	N101	Organization ID Code	2	"SF" (Ship From)
	N102	Name	1-35	Name of Shipper
	N103	ID Code Qualifier	1-2	"1" (Duns) or "91" (Assigned by Seller)
	N104	ID Code	2-17	Code of N103
N1	N101	Organization ID Code	2	"ST" (Ship To)
	N103	ID Code Qualifier	2	"92" (Assigned by Buyer)
	N104	ID Code	3	"094" (D.C. Number – Madera, CA)
			3	"097" (D.C. Number – Madera, CA)
HL	HL01	Hierarchical ID Number	1-12	ID Number within Hierarchical Structure
	HL02	Hierarchical Parent ID	1-12	ID Number of Shipment HL that Order is associated with
	HL03	Hierarchical Level Code	1-2	"O" (Order)
PRF	PRF01	Purchase Order Number	1-10	P.O. Number
	PRF04	Purchase Order Date	8	CCYYMMDD
TD1	TD101	Packaging Code	5	"CTN25", "CTN76", ETC.
	TD102	Lading Quantity	1-7	No. of Cartons for this PO/Store
	TD106	Weight Qualifier (Optional)	1-2	"G" Gross
	TD107	Weight (Optional)	1-10	Total Weight for this PO/Store
	TD108	Unit of Measure Code (Optional)	2	"LB" (Pounds)
REF	REF01	Reference Number Qualifier	2	"DP" (Department)
	REF02	Reference Number	3	Retailer's Dept. Number
N1	N101	Organization ID Code	2	"BY" (Buying Party)
	N103	ID Code Qualifier	2	"92" (Assigned by Buyer)
	N104	ID Code	3	Store Number
HL	HL01	Hierarchical ID Number	1-12	ID Number within Hierarchical Structure
	HL02	Hierarchical Parent ID	1-12	ID Number of Shipment HL that Pack is associated with
	HL03	Hierarchical Level Code	1-2	"P" (Pack)
MAN	MAN01	Marks & Number Qualifier	1-2	"GM" (UCC-128 Serial Shipping Container Code Format)
	MAN02	Marks & Number	20	Number Identifying Pack
HL	HL01	Hierarchical ID Number	1-12	ID Number within Hierarchical Structure

<u>SEGMENT</u>	<u>DATA ELEMENT</u>	<u>LEN</u>	<u>VALUE/COMMENTS</u>	
HL	HL02	Hierarchical Parent ID	1-12	ID Number of Shipment HL that Item is associated with "I" (Item)
	HL03	Hierarchical Level Code	1-2	
LIN	LIN02	Product ID Qualifier	2	"UP" (UPC Code) or "EN" (EAN Code) UPC Code or EAN Code
	LIN03	Product ID Code	1-30	
SN1	SN102	Number of Units Shipped	1-7	Number of Units "EA" (Each), "CA" (Case)
	SN103	Unit of Measurement Code	2	
CTT	CTT01	Line Item Count	1-6	Number of HL Segments
SE	SE01	Total Segments	1-10	Segment Count; includes ST & SE Sequential Number; same as ST02
	SE02	Control Number	4-9	
GE	GE01	Total	1-6	Total of ST Segments Sequential Number; same as GS06
	GE02	Control Number	1-9	
IEA	IEA01	Total	1-5	Total of GS Segments Sequential Number, same as ISA13
	IEA02	Control Number	9	